

Characteristics of Concrete Waste Water and Progress of On-Going Treatment

Zarni Aung¹, Zinmar Chan² and Kyawswa Tun³

¹Department of Chemical Engineering
Technological University (Mandalay)

²Department of Mechanical Engineering
Technological University

³Central Workshop Department
Greatwall Waimar International Compan



Abstract – *The purpose of this study is the examination of the properties of waste water obtained from a ready-mixed concrete plant and its utilization potential as mixing water for concrete production of the batching plant from Great Wall industry, Sagaing Division, Myanmar. The fact that wastewater has detrimental effect on durability of concrete structures is not disputable. Thus durable concrete will retain its original form, quality, and serviceability when exposed to its environment. Samples of waste water from several points of a water recycling process from this ready-mixed concrete plant were examined for their chemical properties (Cl; SO₄²⁻, alkalis, total solids, pH) and compared with the specifications applied for concrete mixing water. Also samples of dry sludge powder from the water-recycling process tank were taken and tested for their chemical composition, particle size distribution, and mineralogical composition and thermo gravimetric results. The water samples were examined for their behavior in concrete specimens with and without admixtures and also for their effect in water demand and setting times in cement pastes. This paper reviews the degradation mechanism of wastewater on ready-mixed concrete structures with a view to finding what needs to be done to salvage these structures. It is obvious that the results of this investigation contribute to the protection of the environment from hazardous waste water disposal and the ready-mixed concrete industry from fresh water costs and any additional cost for buying and conserving an unnecessary complicated water-recycling system.*

Keywords – *Component; Formatting; Style; Styling; Insert.*

I. INTRODUCTION

In most natural environments concrete is durable. However, concrete is sometimes used in areas where it is exposed to substances that can attack and deteriorate it. When reinforced concrete structures are used as transporting media and / or treatment facilities for wastewater; they are exposed to extremely aggressive factors of the environment which could reduce their durability. According to composition of wastewater is a function of its source, which consequently has greater impact on the nature of deterioration expected on reinforced concrete structures.

This problem affects food, agriculture and health in many countries around the globe. Construction of waste water treatment plants and reduction of groundwater submerging appear to be obvious solutions to the worldwide crisis. The reuse of water in highly water consuming industries and units could contribute significantly in overcoming the problem. The construction industry appears to be responsible for the consumption of huge amounts of water. Potential disintegrating agents in wastewater generated in Myanmar were identified and common degradation effects were examined.

Regeneration, preventive and corrective techniques were noted. All test showed that waste water is suitable for concrete mixing water and that it can be used without any treatment or dilution, thus contributing to water saving. Waste water from ready-mixed concrete plants is classified as waste hazardous for disposal due to its high pH value (over 11.5). Very few ready-mixed concrete plants that recycle waste water follow a complicated process through multiple overflows and a stage of neutralization, with HCl addition. One of such approaches is to use admixtures, which could reduce the effect of acidic attack common in wastewater concrete structures: This paper have analyzed the treatment systems of waste water from concrete batching plant of Great Wall Industry construction, Maung Kone, Sagaing Division in Myanmar.

1.2. Generation and Composition of Waste

Specifications for mixing water used in the production of hydraulic cement concrete (American Society for Testing and Materials,2006) and the EN standard for mixing water for concrete (European Committee for Standardization, 2002), there are optional limited values of maximum concentration in the mixing water for chloride, sulfate, alkalis and total and total solids by mass.



Chart-1 Batching Plant of Great Wall Construction

Myanmar is mainly an agricultural and developing country. Moreover, our country Myanmar is mainly description for rural development, transportation is also important fort. Being the developing country, we have to use concrete for urbanization and industrialization which are the impetus for economic growth, large quantities of industrial wastewater are equally generated. Different researchers had characterized the nature of wastewater generated in Myanmar.



Chart-2 Concrete Waste Water Tank of Great Wall Construction

The subsequent sections of this paper show how these agents, organic and non-organic substances, in the wastewater affect reinforced concrete applications.

There are no limits for maximum pH values, but the suitability of the waste water as mixing water in concrete is controlled mainly by the produced concrete performance.

It has tested the samples form the process in the ready-mixed concrete plant. These are 4 numbers such as TH₂O₁, TH₂O₂, TH₂O₃, TH₂O₄ and T_c. is water received from the first wash out of the truck, TH₂O₂ is from the second truck) TH₂O₃ is wash water from second + ank. TH₂O₄ is in the third tank and T_c is combined waste (0-20 percent wash water and 80-100 percent fresh water.

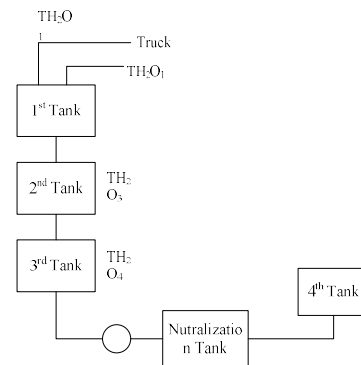

Chart-3 Process of Water Treatment for Concrete Waste

It is obvious that all water samples, even those taken directly from the truck washout (TH₂O₁ and TH₂O₂) meet with the standard maximum concentration limits for mixing water according to ASTM (American Society for Testing and Materials, 2006) and EN (European Committee for Standardization, 2002).On the contrary, none of the samples. Not even the one used for concrete production (CW), meet with the Hellenic specifications (ELOT,1979) which means that it is very difficult for Myanmar ready-mixed concrete plants to use more recycled water.

Concerning the chemical properties of the water samples, it is noticed that all water samples exceed the pH value of 11.5 thus should be classified as hazardous wastes and must not be disposed according to European and US legislation. Also, a progressive reduction of total solids and sulfate’s concentration is observed from the first to third tank, unlike the relative constancy of alkalis and chlorides which is noticed in all waste water samples.

1.3. Composition in Sludge

As mentioned before, the first tank in figure 1 is consisted mainly by solids, which are the sludge of the washout water from the trucks. This sludge shape a white agglomerated fine material that is discharged every time the tank is filled up. To determine the characteristics of this material, a chemical analysis took place, using X-Ray Fluorescence (XRF).

The chemical analysis shows that the sludge mainly consists of CaO and has a significantly high loss on ignition that implies the presence of large amounts of calcite (CaCO₃) coming from the fine fractions of the sand of Hellenic calcareous aggregates. This observation was verified by XRD analysis as shown below.

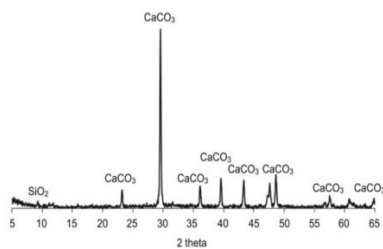

Chart-4 XRD diagram of Sludge in first tank

Table -1: Chemical Composition of Sludge

No	Element oxide	Concentration (%)
1	CaO	41.1
2	SiO ₂	10.5
3	AL ₂ O ₃	5.02
4	MgO	1.82
5	Fe ₂ O ₃	1.43
6	SO ₃	1.25
7	K ₂ O	0.2
8	TiO ₂	0.92
9	LOI	36.9

1.4. Concrete Specimens

The main requirement from concrete mixing water is for it not to reduce concrete strength or entirely change cement’s setting times. To examine the above requirements concrete specimens were made according to the mixing proportions given in Table 2.

Table -2: Particle Distribution analysis of sludge

No	Sieve Size (m)	Quantity Passing (%)
1	250	46.0
2	500	59.2
3	800	68.4
4	1000	70.3
5	2000	99.4

It is obvious that waste water, not only does not reduce 7 day compressive strength below 90 percent of the control specimens strength, but in most cases it shows a slight improvement. It also seems that admixtures react better with waste water leading to a rise in compressive strength

1.5. Result and Discussion

The case study involved wastewater discharged from concrete manufacturing. The process involves raw material (polymers) melting unit, forming the pattern in special concrete is sprayed with special dyes and solvents. Wastewater discharged from the department was characterized by the high contents of organic compounds.

Myanmar generates large volume of wastewater and that many of the concrete structures used in handling the waste are fast degrading due to the deteriorating impact of waste water and poor maintenance. However, the characterization was with a view to treating the wastes in order to safeguard public health rather than studying the effect on concrete. Most techniques required in preserving wastewater reinforced concrete structures are not available locally and where available are not cost effective.

Further research is needed to characterize wastewater generated in Myanmar with the purpose of identifying the classes of sulphate reducing bacteria and other concrete degrading agents.

Table -3: Cement Paste Properties

Used water sample	Measured Values			Normalized Values (%)		
	Initial setting time (min)	Final setting time (min)	Water Demend (ml)	Initial setting time (min)	Final setting time (min)	Water Demend (ml)
TH203	140	190	27.1	100	90.1	98.0
TH204	130	185	26.8	93	87.2	97.8
De-ionized	132	200	27.1	95.1	95.0	97.2

Studies aimed at quantifying the damaging effect of wastewater generated in concrete batching plant, in Great wall Industry, Maung Kone, Myanmar. And its sewer pipes and other concrete wastewater utilities will require concreted efforts and multidisciplinary approach. A key policy priority should therefore be to encourage the use of pozzolanic materials that could resist sulphuric acid attack in concrete.

II. CONCLUSION

Characteristics of concrete wastewater determine the adequate treatment system, specifically, solubility, toxicity and biodegradability of the pollutants. In chemical, waste waters decreases the concentration and toxicity of the pollutants and is cost effective since no chemical salts are required to provide nutrients in treatment system. The rotating biological contactor is a simple in operation and management a highly effective system.

Nowadays, there is so much scarcity of water. Therefore there is need to arrange other sources of water for concrete or construction of building units. Thi spaper is about tread-waste water which now a day drains in river can use in concrete.

ACKNOWLEDGEMENT

Firstly, the authors gratefully acknowledge to the members of construction groups, Great wall Industry, Maung Kone, Sagaing Division in Myanmar. The authors would like to express their gratitude to all those who were directly or indirectly involved in the successful completion of this research work.

REFERENCES

- [1] Lateef, A. The microbiology of pharmaceutical effluent ant its public health implications. World J. MicrobiolBiothechnol. Vol. 20,2004, pp. 167-171.
- [2] EI-Gohary, F. A., Abo-Elela S.I. and Ali H. I. Management of wastewater from soap and food industries: a case study . Sci Total Environ. Vol. 66,1987, pp. 203-212.
- [3] Ma, A.N. Enviromental management for the palm oil industry. Palm Oil Dev. Vol.30 2000,pp.1-9
- [4] Saricimen H, Shameem M, Barry M.S.,Ibrahim M. and Abbasi T.A. Durability of proprietary cementitious materials for use in wastewater transport system. CemConcr Comp. Vol. 25, Number 4, 2011,pp.421-427
- [5] Siyanbola, T. O., Ajanaku, K. O., James, O. O., Olugbuyiro, J. A. O. and Adekoya, J. O. Physicochemical characteristics of industrial effluents in Lagos State, Nigeria. G. J. P&A Sc and Teah. Vol. 1,2011,pp.49-54.
- [6] Americal Society for Testing and Materials (2006) “ Standard Specification for mixing water used in the production of hydraulic cemerial conerate “, ASTM